

PHOENIX DOUBLE

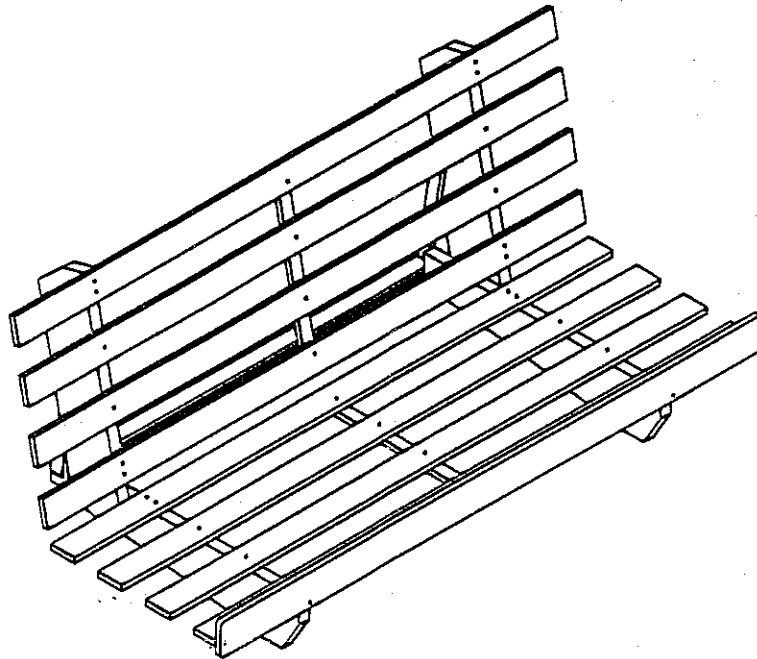

LIST OF MATERIALS			
ITEM	DESCRIPTION	# REQ.	COMMENTS
1.	FACEPLATE	1	FASTEN TO FRONT LEGS; LONG PORTION UP
2.	SWINGBAR	1	FASTEN TO BOTTOM END OF UPRIGHT STICKS
3.	50mm WOOD SCREW	4	TO ATTACH FACEPLATE AND SWINGBAR

- (A) BEGIN ASSEMBLY USING THE PHOENIX S.E. INSTRUCTIONS WHICH ARE SUPPLIED WITH THIS FRAME AS WELL
- (B) THIS INSTRUCTION SHEET DESCRIBES THE **ADDITIONAL** ASSEMBLY REQUIREMENTS OF THE PHOENIX DOUBLE FRAME

HELPFUL HINT: APPLY A SMALL AMOUNT OF BAR SOAP TO THE WOOD SCREW THREADS TO HELP EASE ASSEMBLY

NOTE: AFTER FINAL ASSEMBLY, RETIGHTEN ALL SCREWS FIRMLY TO ENSURE PROPER FUNCTION OF UNIT

STEP 1: ASSEMBLE SWINGBAR USING
50mm WOOD SCREWS

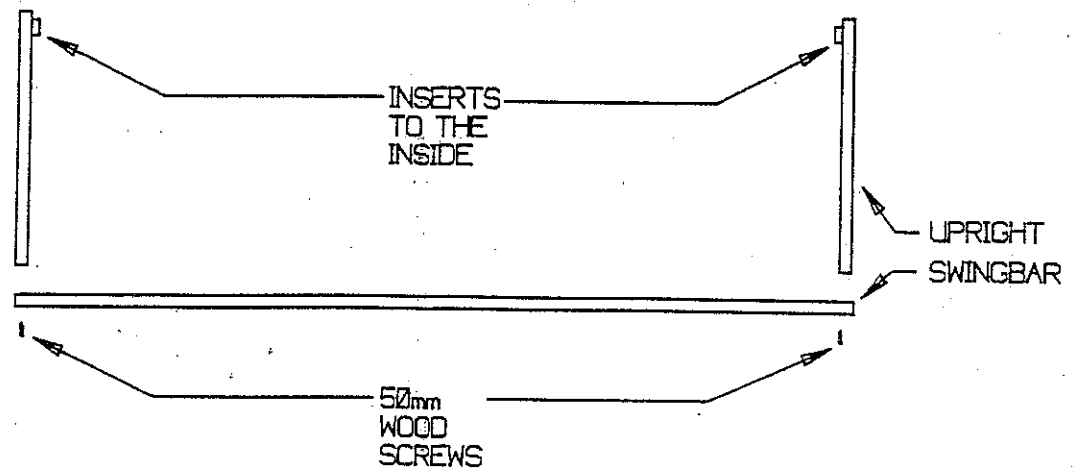

STEP 2: FASTEN FACEPLATE TO
FRONT LEGS USING 2
50mm WOOD SCREWS

LONGER PORTION OF FACEPLATE
MUST GO UP

BE SURE T NUT INSERTS ARE
TO THE INSIDE OF FRONT LEGS

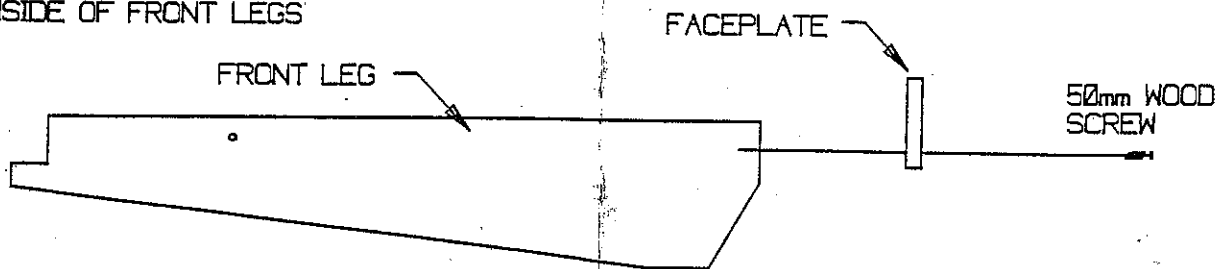

STEP 3 :

UPRIGHT ATTACHED HERE
USING A 60mm PIN

LEGS ATTACHED HERE
USING AN 80mm PIN

