

LIST OF MATERIALS

ITEM	DESCRIPTION	# REQ.	COMMENTS
1.	4mm ALLEN KEY	2	TO TIGHTEN ALL SCREWS & PINS SECURELY
2.	T NUT INSERT	8	INSTALL CAREFULLY AS PER STEP 1 PG 2
3.	40mm PIN	4	TO FASTEN SUPPORT STICKS TO SLATS
4.	60mm PIN	2	TO FASTEN UPRIGHT STICKS TO BACK LEGS
5.	80mm PIN	2	TO FASTEN LEGS TOGETHER
6.	50mm WOOD SCREW	24	TO FASTEN SLATS TO LEGS
7.	1 1/2" QUADREX SCREW	4	TO FASTEN SLATS TO SUPPORT STICKS
8.	BACK LEG	2	TO OUTSIDE OF FRONT LEG (SEAT)
9.	FRONT LEG	2	INSTALL INSERTS TO INSIDE FACES
10.	SUPPORT STICK	2	ATTACH UNDER PLATFORM SLATS
11.	UPRIGHT STICK	2	ATTACH TO INSIDE OF BACK LEGS
12.	BACK SLAT-5 HOLE	2	PUT CENTER HOLE OF SLAT TO INSIDE EDGE
13.	BACK SLAT-3 HOLE	2	CENTER HOLE FOR QUADREX SCREW
14.	FRONT SLAT-5 HOLE	2	PUT CENTER HOLE OF SLAT TO INSIDE EDGE
15.	FRONT SLAT-3 HOLE	2	CENTER HOLE FOR QUADREX SCREW
16.	STRIP OF FOAM OR GRIPPER	1	OPTIONAL PURCHASE

YOU WILL ALSO REQUIRE: A HAMMER AND EITHER A PHILLIPS OR ROBERTSON SCREWDRIVER

HELPFUL HINT: APPLY A SMALL AMOUNT OF BAR SOAP TO THE WOOD SCREW THREADS TO HELP EASE ASSEMBLY

NOTE: AFTER FINAL ASSEMBLY, RETIGHTEN ALL SCREWS FIRMLY TO ENSURE PROPER FUNCTION OF UNIT

STEP 1: HAMMER T NUT INSERTS (SEE DETAIL A) INTO UPRIGHTS, FRONT LEGS, AND SUPPORT STICKS (SEE DETAIL B ON PAGE 4)

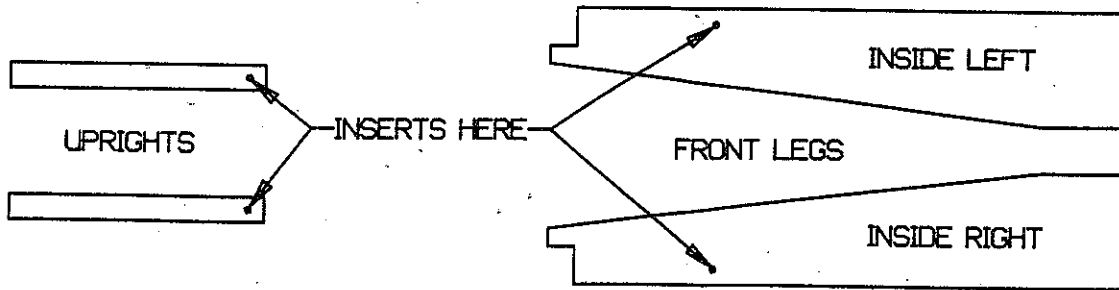

NOTE:

BE SURE TO MAKE RIGHT HAND AND LEFT HAND AS SHOWN

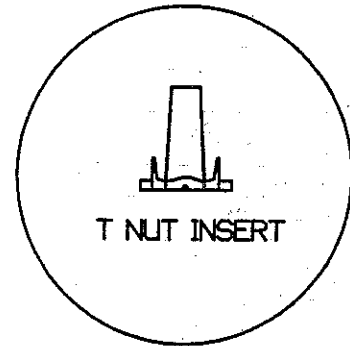
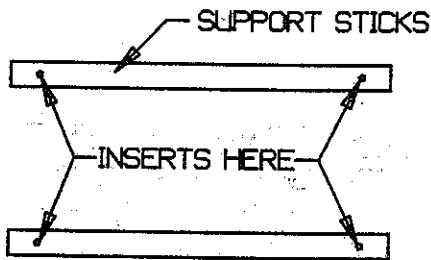

DETAIL A

NOTE: HOLE SPACINGS ON PLATFORM SLATS ARE DIFFERENT

BACK PLATFORM HOLES ARE FARTHER APART

FRONT PLATFORM HOLES ARE CLOSER TOGETHER

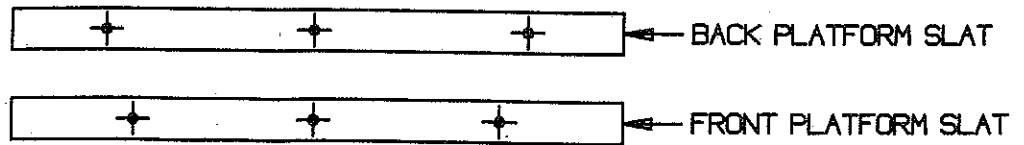

ALSO: 5 HOLE SLATS GO TO THE OUTSIDE OF THE PLATFORM (CENTER HOLE TO THE INSIDE)
3 HOLE SLATS ARE CENTRALLY LOCATED IN THE PLATFORM

STEP 2a: LOOSELY FASTEN FRONT SLATS TO FRONT LEGS USING 50mm WOOD SCREWS (BE SURE YOU HAVE THE CORRECT SLATS)

STEP 2b: FASTEN SUPPORT STICK TO UNDERSIDE OF FRONT SLATS USING 2 40mm PINS (SHORTEST) (SEE DETAIL B ON PAGE 4)

STEP 2c: FASTEN BOTH MIDDLE FRONT SLATS TO SUPPORT STICK USING 1 1/2" QUADREX SCREWS

STEP 2d: TIGHTEN ALL SCREWS FIRMLY

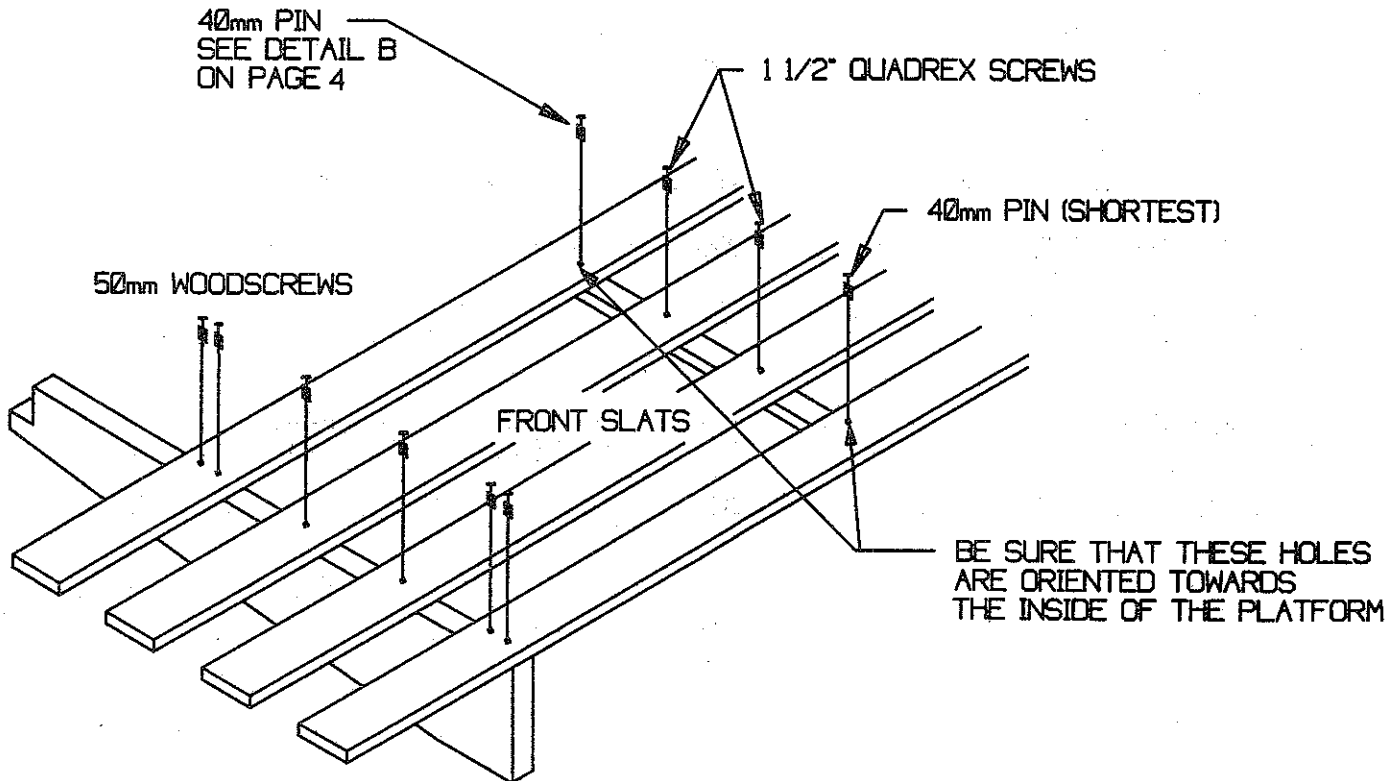

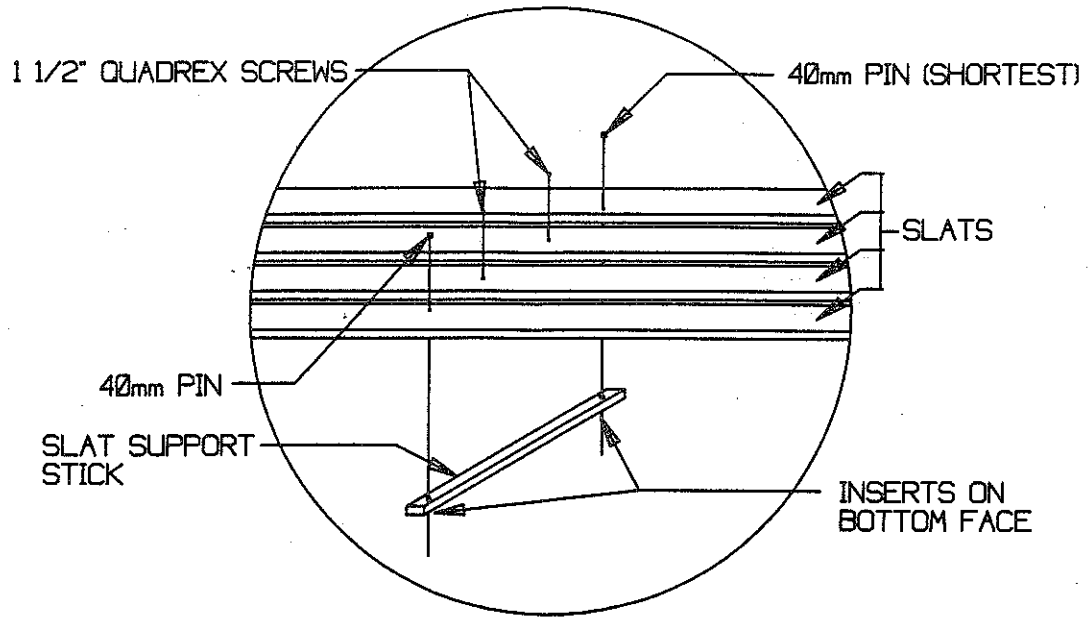

DETAIL B

STEP 3a: FASTEN BACK LEGS TO OUTSIDE OF FRONT LEGS USING 80mm PINS (LONGEST)

STEP 3b: FASTEN UPRIGHTS TO INSIDE OF BACK LEGS USING 60mm PINS

STEP 4: REPEAT STEPS 2a THRU 2d FOR BACK SLATS AND BACK LEGS

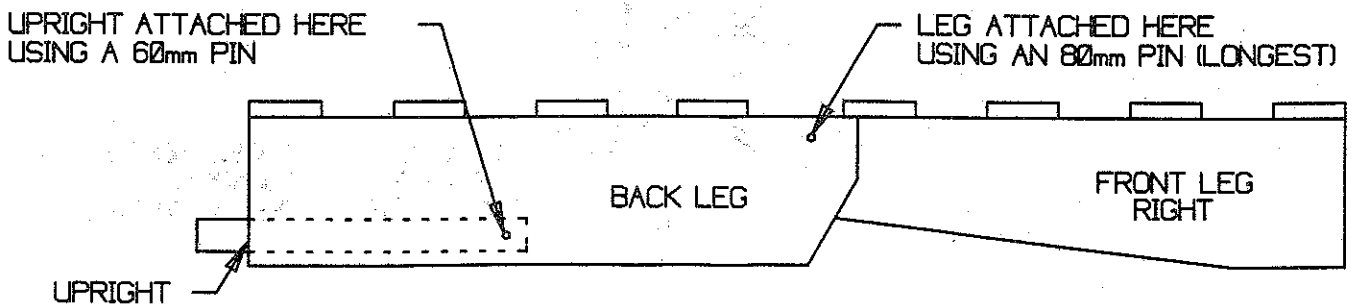

OPTIONAL: PLACE FOAM STRIP OR GRIPPER ON SEAT SLATS BEFORE PUTTING FUTON CUSHION IN PLACE PURCHASE. THIS WILL HELP TO PREVENT THE FUTON FROM SLIDING FORWARDS OFF SLATS